

THE AQUA CREEK PRODUCTS STANCHION POSTS ARE DESIGNED FOR USE WITH PENNANT LINES. EACH STANCHION POST MEASURES 96" IN TOTAL LENGTH AND MAY ALSO BE USED FOR ACCESSORY ATTACHMENTS WHEN PAIRED WITH THE STANCHION POST SLIDING RING – PART# INV04314 (SOLD SEPARATELY).

THE AQUA CREEK PRODUCTS STANCHION POST SHALL BE FABRICATED OF 1.90" O.D. X .145" WALL THICKNESS 316L STAINLESS STEEL. THE STANCHION POST SHALL BE POLISHED TO A NEAR #7 FINISH OR 600 GRIT.

EACH STANCHION POST SHALL BE SUPPORTED BY ONE (1) 6" BRONZE ANCHOR – PART# INV01926 (NOT INCLUDED). AN OPTIONAL STAINLESS STEEL ESCUTCHEON – PART# INV03705 (NOT INCLUDED) – IS ALSO AVAILABLE FOR A CLEAN, FINISHED APPEARANCE.

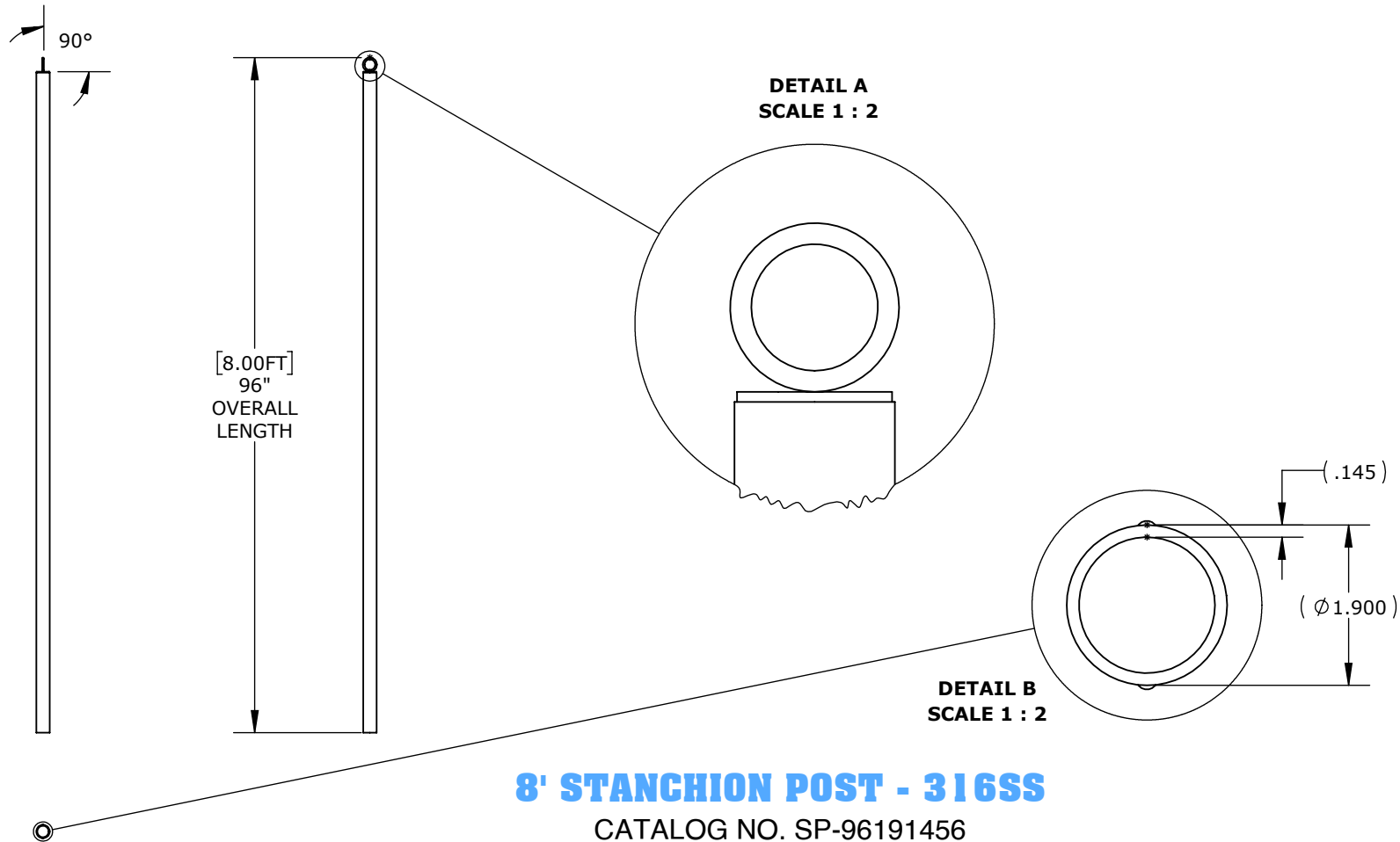

8' STANCHION POST - 316SS

CATALOG NO. SP-96191456
PART NO. INV04312

MODEL
1
REVISION

8' STANCHION POST - 316SS - INV04312

SCALE
1:24
SHEET
1



9889 GARRYMORE LANE
MISSOULA, MT 59808
(406) 549-0769
FAX (406) 549-2602
www.AquaCreek.com

PROPRIETARY AND CONFIDENTIAL INFORMATION
THIS DRAWING AND ALL INFORMATION CONTAINED HEREIN IS THE SOLE PROPERTY OF AQUA CREEK PRODUCTS LLC. ANY REPRODUCTION IN PART OR AS A WHOLE WITHOUT WRITTEN PERMISSION FROM AQUA CREEK IS PROHIBITED.
*SPECIFICATIONS ARE SUBJECT TO CHANGE WITHOUT NOTICE

DIMENSIONS ARE IN INCHES
UNLESS OTHERWISE SHOWN
FRACTIONAL: ±1/16
ANGULAR: ±1°
TWO PLACE DECIMAL: ... ±.01
THREE PLACE DECIMAL: .. ±.005

MATERIAL: 316L STAINLESS STEEL
FINISH: 600 GRIT OR NEAR #7
APPROX. WEIGHT: 21.86 LBS.