

SPECIFICATIONS:

THE AQUA CREEK PRODUCTS' 500LB HEAVY-DUTY SLING BAR SHALL BE MADE TO WORK WITH THE REVOLUTION SLING-ARM AND THE HEAVY DUTY SLING AND CHAINS. THE SLING BAR SHALL HAVE A RATED CAPACITY OF 500LBS [227KG]. IT SHALL BE MADE FROM TYPE 304 STAINLESS STEEL AND SHALL BE POWDER COATED FOR ADDED CORROSION RESISTANCE. THE HEAVY-DUTY SLING BAR SHALL HAVE A 30 3/8" [77.1cm] WIDE MOUNTING DIMENSION, TO BE USED WITH EXTRA WIDE HEAVY DUTY SLINGS WITH A 500LB [227KG] MINIMUM RATED CAPACITY.

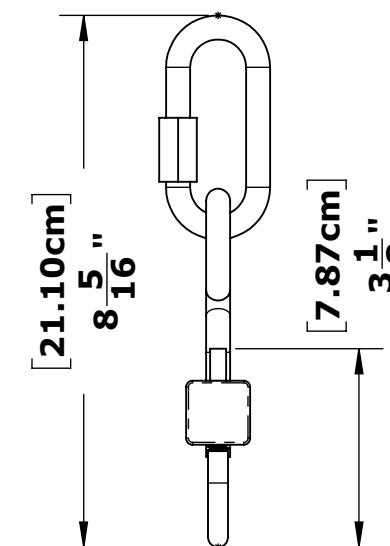
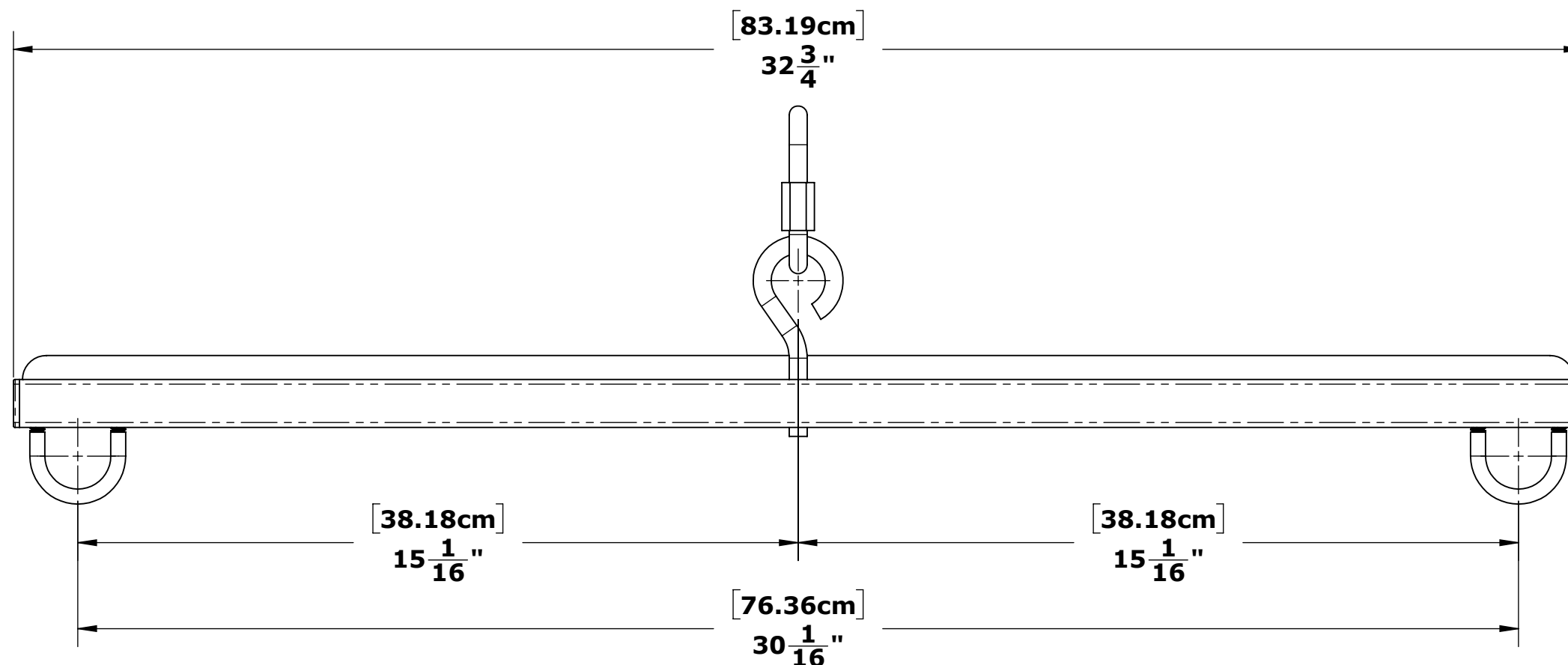
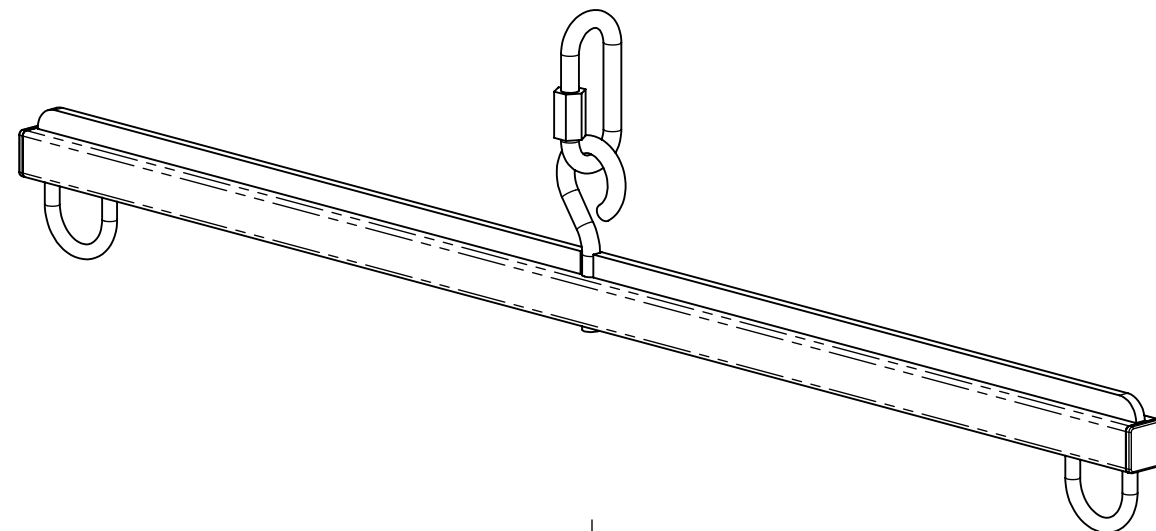

TOLERANCES

DIMENSIONS ARE IN INCHES
UNLESS OTHERWISE SHOWN
FRACTIONAL: ±1/16
ANGULAR: ±1°
TWO PLACE DECIMAL: ±.01
THREE PLACE DECIMAL: .. ±.005

HANGER BAR - HEAVY DUTY

F-030EZHB
PART NO. INV01381

MATERIAL: 304 STAINLESS STEEL
FINISH: POWDER COAT - WHITE
APPROX. WEIGHT: 5.20 LBS.



9889 GARRYMORE LANE
MISSOULA, MT 59808
(406) 549-0769
FAX (406) 549-2602
www.AquaCreek.com

PROPRIETARY AND CONFIDENTIAL INFORMATION

THIS DRAWING AND ALL INFORMATION CONTAINED HEREIN IS THE SOLE PROPERTY OF AQUA CREEK PRODUCTS LLC. ANY REPRODUCTION IN PART OR AS A WHOLE WITHOUT WRITTEN PERMISSION FROM AQUA CREEK IS PROHIBITED.

*SPECIFICATIONS ARE SUBJECT TO CHANGE WITHOUT NOTICE

REVISIONS			
REV.	DESCRIPTION	DATE	APPROVED
P1	INITIAL RELEASE	10/6/2021	J.MAXWELL

SCALE
1:3

SHEET
1

HANGER BAR - HEAVY DUTY - INV01381

51-163-220